



Installation Instructions

Dynarail[®] Safety Ladder System

Corrosion Resistant

Nonconductive

Fire Retardant

High Strength-To-Weight Ratio

Long, Low Maintenance Life

*Meets OSHA, BOCA & Other
Building Code Requirements*

Fibergrate

Composite Structures

High Performance Composite Solutions



Simplified Ladder Instructions



The **Dynarail® Safety Ladder System** has been designed to combine the best in fiberglass reinforced plastic (FRP) ladders and cages with simplicity of installation. Fibergrate has made every attempt to provide clear and thorough instructions for installing these products. If you have any further questions, or need additional information, do not hesitate to contact Fibergrate at 800/527-4043.

By following the simple instructions in this folder, you should find installation of your handrail system quick and easy.

TOOLS REQUIRED

- Drill**
- Bits -**
 - **1/8"** (for rivets)
 - **3/16"** (for kickplate screws)
 - **9/16" & 11/16"** (for connection bolts)
- 25' Tape Measure**
- Sealing Kit**
- Bonding (Epoxy) Kit(s)**
- Sandpaper (80 grit)**
- Wrenches -**
 - **7/16"** (2 each)
 - **9/16"** (2 each)
- Hack Saw**
- Level**
- Stir Sticks**
- "C" Clamps**

NOTE: Cuts and drilled holes must be sealed to maintain corrosion protection.



QUICK TIPS FOR INSTALLING LADDERS

1. Layout ladder, walkthru, wall mount kits and floor mount kits. Cut ladder as required (see **Section 1 - Installing Ladder and Walkthru**). Attach walkthru to ladder (see **Section 1 - Installing Ladder and Walkthru**). Attach wall mounts to ladder and mount on wall (see **Section 1 - Installing Ladder and Walkthru - To Install Wall Mounts**). Attach floor mount clip to ladder and bolt to floor (see **Section 1 - Installing Ladder and Walkthru - Installing Floor Mounts**).
2. If installing cage, after installation of the ladder, follow the instructions shown in **Section II - Installing Cage** for installation of hoop brackets, hoops and vertical bars.

IMPORTANT

It is the installer's responsibility to carefully follow fabrication and installation plans and instructions to ensure design performance characteristics of the Dynarail® ladder system.

The installer could be liable for claims that result from improper installation.

**DRAWING A -
INSTALLED LADDER**

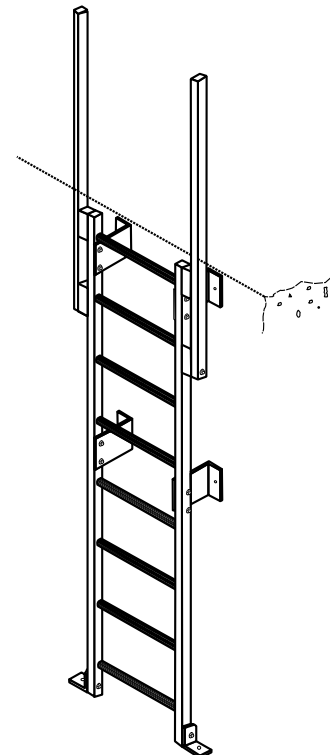

Section I - Installing Ladder

DRAWING B - VARIABLE & FIXED DIMENSIONS

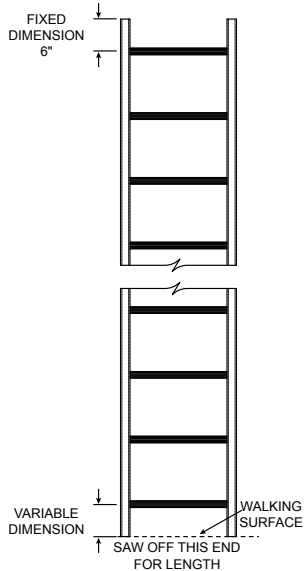

DRAWING C - LADDER RAIL SPLICE

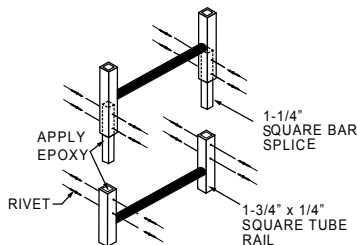

DRAWING D - WALKTHRU WITH SPLICES

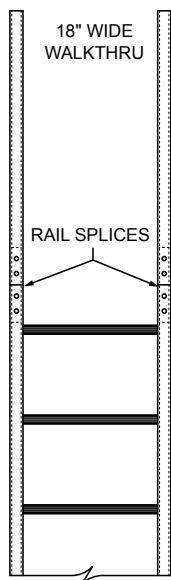

INSTALLING LADDER AND WALKTHRU

1. Determine required ladder height by measuring from walking surface at bottom of ladder to step-off at top of ladder. Add 6 inches to obtain the required overall ladder length. Any adjustment in the ladder length should be made at the ladder bottom (walking surface end - see **Drawing B**). For example, if the overall ladder length determined is 8'5" and you are working with a 10' ladder, be sure 6 inches are left from the step-off rung to the top and cut 1'7" from the opposite end (see **Drawing AB**).
2. If installing the standard 18" wide walkthru, mix and apply epoxy to splice end (see **Drawing C**) of one of the walkthru posts and insert splice end into the ladder siderail at the top end (see **Drawing D**). Drill for, and install, 4 rivets - 2 on each side of rail. Repeat with other post.

If installing the 24" wide walkthru, place top spacer of one walkthru post as shown in **Drawing E**, drill and bolt loosely into place. Place the bottom spacer in place, match drill and bolt into place. Tighten all bolts. Repeat with other walkthru post.

INSTALLING WALL MOUNT BRACKETS

Note: Maximum 6' spacing between brackets and maximum 6' from bottom end of ladder to first bracket. Ladder must be attached to wall or structure at the top rung.

3. With pencil, mark location on wall and ladder where brackets are to be mounted.
4. Locate end of the first wall mount flush with front edge of ladder (**Drawing F**). Match drill two 7/16" diameter holes in ladder rail and bolt bracket to ladder with 3/8" x 3" hex head bolt assemblies. Continue with all wall mount brackets.
5. Drill wall for anchor bolts.
6. Mount ladder to wall with top rung flush with step-off.

INSTALLING FLOOR MOUNT CLIPS

Note: If floor mount cannot be used, substitute bottom wall mount (**Drawing G**) and install at bottom of ladder using steps 3 - 6.

7. Place the floor clip flush with bottom of ladder rail, mark holes in bottom of ladder rail and drill a 7/16" diameter hole (**Drawing H**). Repeat for opposite rail. Bolt floor clips to ladder with 3/8" x 3" hex head bolt assemblies.
8. Drill floor for anchor bolts.
9. Bolt ladder to floor (**Drawing H**).

DRAWING E - WALKTHRU WITH SPACERS

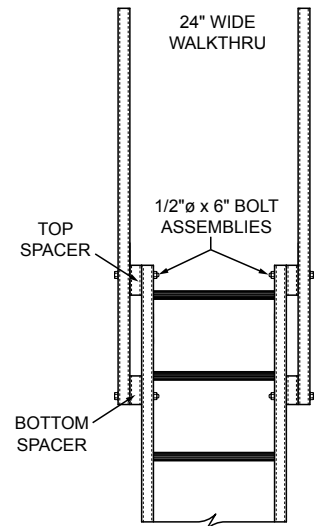

DRAWING F - STANDARD WALL MOUNT

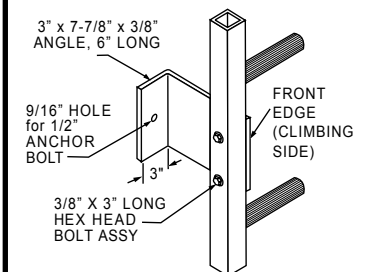

DRAWING G - BOTTOM WALL MOUNT

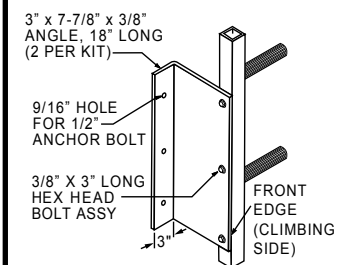

DRAWING H - FLOOR MOUNT

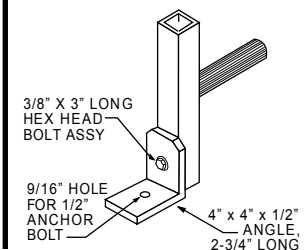

Section II - Cage Installation

DRAWING I - TOP AND BOTTOM CAGE HOOPS

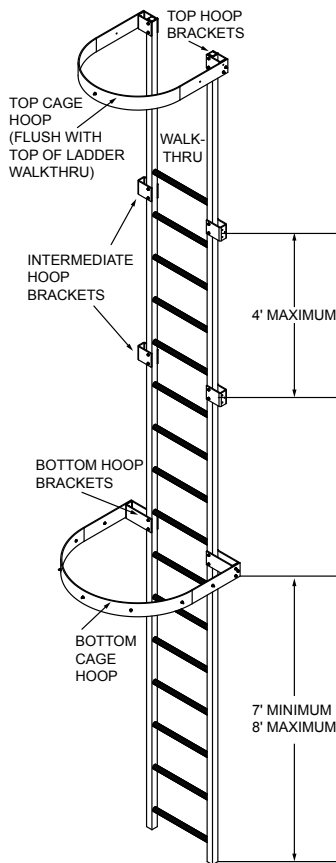

DRAWING J - VERTICAL BAR CONNECTION

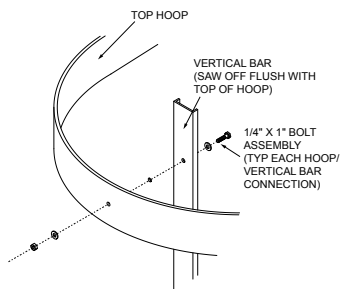

DRAWING K - VERTICAL BAR SPLICE

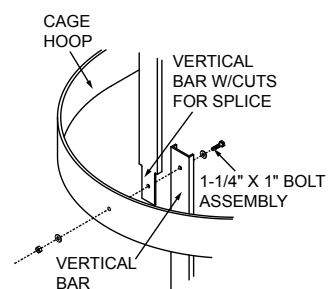

1. If your ladder has an 18" wide walkthru, locate top cage hoop bracket flush with inside edge and top of ladder square tube rail (**Drawing I**). If your ladder has a 24" wide walkthru, eliminate the top cage hoop brackets and attach the hoops directly to the walkthru rails using 1/4" x 2-1/2" round head bolts. Proceed as for 18" wide walkthru with remaining installation.
2. Using cage hoop brackets as templates, drill 5/16" diameter mounting holes through the ladder rail. Bolt top hoop brackets to the ladder using the 1/4" x 3" round head bolt assemblies provided.
3. Locate bottom hoop brackets by measuring from outside of top bracket to outside of bottom cage bracket for cage height (**Drawing I**). Bottom hoop bracket should be 7' minimum, 8' maximum from walking surface at bottom of ladder. **Remember, hoops should be maximum 4' apart (see step 5).**
4. Using bottom hoop brackets as templates, drill and bolt intermediate hoop brackets to ladder using the 1/4" x 3" round head bolt assemblies provided.
5. After all brackets are attached, mount the cage hoops to the brackets using the 1/4" x 1-1/4" bolt assemblies provided (**Drawing I**).
6. Install the vertical bars beginning at the bottom hoop by centering vertical bar over the hole in the hoop, match drilling a 5/16" diameter hole, and bolting with the 1/4" x 1" long bolt with two flat washers and hex nut (**Drawing J**). Continue with the remaining hoops (**Drawing L**). (If vertical bars are not long enough, splice per **Drawing K**). Saw the bar flush with the top hoop.
7. Repeat step #6 until all seven vertical bars are installed.
8. Continue with steps #3 through #9 to finish your Dynarail FRP ladder system installation (**Drawing M**).

DRAWING L - VERTICAL BAR INSTALLED

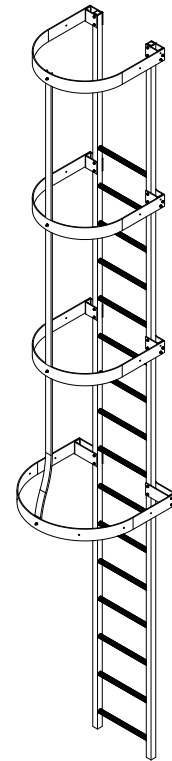

DRAWING M - INSTALLED LADDER WITH CAGE

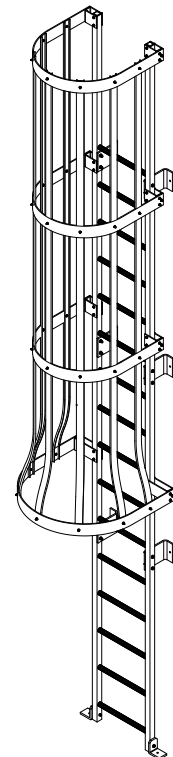

Section III - Technical Information

OSHA REQUIREMENTS FOR LADDERS AND LADDER SYSTEMS

From the Code of Federal Regulations dated July 1, 1995, Title 29, Labor, 1910.27

Installer is responsible for referring to most current OSHA Code for complete information.

1. (a)(1)(i) 200 lb concentrated load (minimum at center of rung)
2. (b)(1)(ii&iii) Distance between rungs maximum 12", minimum clear length of 16"
3. (c)(4) Distance from the centerline of rungs to wall in back of ladder shall be not less than 7"
4. (d)(1)(ii) Cage required on ladders of more than 20' to a maximum unbroken length of 30'
5. (d)(1)(iii) Cage to extend minimum of 42" above top of landing
6. (d)(1)(iv) Cage shall begin minimum 7' to maximum 8' above base of ladder (floor)
7. (d)(1)(v) Cage shall not be less than 27" in width
8. (d)(1)(v) Cage hoop vertical bars shall be located at a maximum spacing of 40° around the circumference of the cage.

TECHNICAL DATA

(All materials are yellow isophthalic polyester, fire retardant)

LADDER:

Maximum length without splice	24'-0"	Outside Diameter of rung	1-1/4"
Maximum ladder length with cage	33'-6"	Inside Diameter of rung	7/8"
Inside width (inside rail to rail)	18"	Rail - outside width	1-3/4"
Outside width (outside rail to rail)	21-1/2"	Rail - wall thickness	1/4"
Rung Spacing (center to center)	12"	Weight per foot (approximately)	2.7 lbs.

CAGE:

Product	Description
Top Hoop	27" from center line of ladder rung to inside of hoop
	3" wide x 1/4" thick hand lay-up
	Predrilled holes
Intermediate Hoop	27" from center line of ladder rung to inside of hoop
	3" wide x 1/4" thick hand lay-up
	Predrilled holes
Bottom Hoop	31" from center line of ladder rung to inside of hoop
	3" wide x 1/4" thick hand lay-up
	Predrilled holes
Hoop Brackets	1/4" thick, "U" shaped hand lay-up
	Predrilled holes
Vertical Bars	Channel-shaped, 2" deep x 9/16" flange x 1/8" thick
Bottom Wall Mount Bracket*	3" x 7-7/8" x 3/8" angle, 18" long
	Two per set
Wall Mount Bracket*	3" x 7-7/8" x 3/8" angle, 6" long
	7" from wall to center of rung
	Two per set
Floor Mount Clip*	4" x 4" x 3/8" angle, 2-3/4" long
	Two per set

***NOTE:** *Wall mount brackets and floor mount clips are predrilled with 9/16" diameter holes for 1/2" diameter anchor bolts only.*

Fibergrate Products & Services

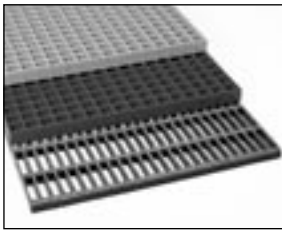

Fibergrate® Molded Grating

Fibergrate molded gratings are designed to provide the ultimate in reliable performance, even in the most demanding conditions. Fibergrate offers the widest selection in the market with more than ten resins including Chemgrate CP-84 and more than twenty grating configurations available in many panel sizes and surfaces.

RIGIDEX® Moltruded® Grating

RIGIDEX Moltruded gratings are the first fiberglass gratings to combine the corrosion resistance of molded grating with the longer span capacity of pultruded grating, all at the low cost of metal gratings.



Safe-T-Span® Pultruded Industrial and Pedestrian Gratings

Combining corrosion resistance, long-life and low-maintenance designs, Safe-T-Span provides unidirectional strength for industrial and pedestrian pultruded grating applications.

Dynarail® Handrail

Easily assembled from durable prefabricated components or engineered to your specifications, Dynarail handrail meets or exceeds OSHA and strict building code requirements for safety and design.



Dynarail® Safety Ladder System

Easily assembled on site, Dynarail safety ladder systems meet or exceed OSHA requirements. Though less costly than prefabricated ladder systems, these safety ladders provide a custom fit to the supporting structure.

Dynaform® Structural Shapes

Fibergrate offers a wide range of pultruded structural components for industrial use, including bars, rods, tubes, beams, channels, leg angles and plates.

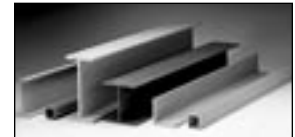

Stair Solutions

Fibergrate offers a wide range of slip-resistant products to meet your stair safety needs. These durable products which include treads, tread covers and covered stair treads are a long-term, cost-efficient solution for your facility.

Grating Pedestals

Uniquely designed adjustable single and quad head pedestals for square mesh molded grating are manufactured to provide safe and economical support for elevated flooring.



Engineering and Fabrication Services

Combining engineering expertise with an understanding of fiberglass applications, Fibergrate provides turnkey design and fabrication of fiberglass structures, including platforms, catwalks, stairways and test racks.